

BMW S 1000XR '20-

REF 21241N

TAPAS LATERAL IZQUIERDO / LEFT SIDE COVERS



1 Person



30 min



EASY

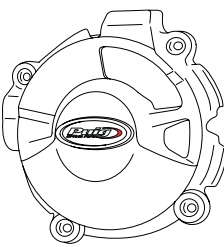
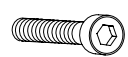

ID.	PIEZA / PART	DESCRIPCIÓN	DESCRIPTION	QTY.	REF.:
1		Tapa izquierda	Left cover	1	CONJUNTO--21241
2		Tornillo M6x40 DIN912	M6x40 DIN912 screw	4	-

RECOMENDAMOS MONTAR LOS TORNILLOS APRETANDO UNIFORMEMENTE UNO TRAS OTRO, PARA APRETAR FINALMENTE CON DINAMOMÉTRICA
WE RECOMMEND TO MOUNT THE SCREWS UNIFORMLY TIGHTENING ONE AFTER THE OTHER, TO FINALLY TIGHTEN WITH DYNAMOMETRIC

BMW S 1000XR '20-

REF 21241N

INSTRUCCIONES DE MONTAJE - MOUNTING INSTRUCTIONS - MONTAGEANLEITUNG

1

ASSEMBLY
MONTAJE

2



3,00 N/m + ángulo giro 90° - Par de apriete
2,21 lbf/ft + turning angle 90° - Tightening torque

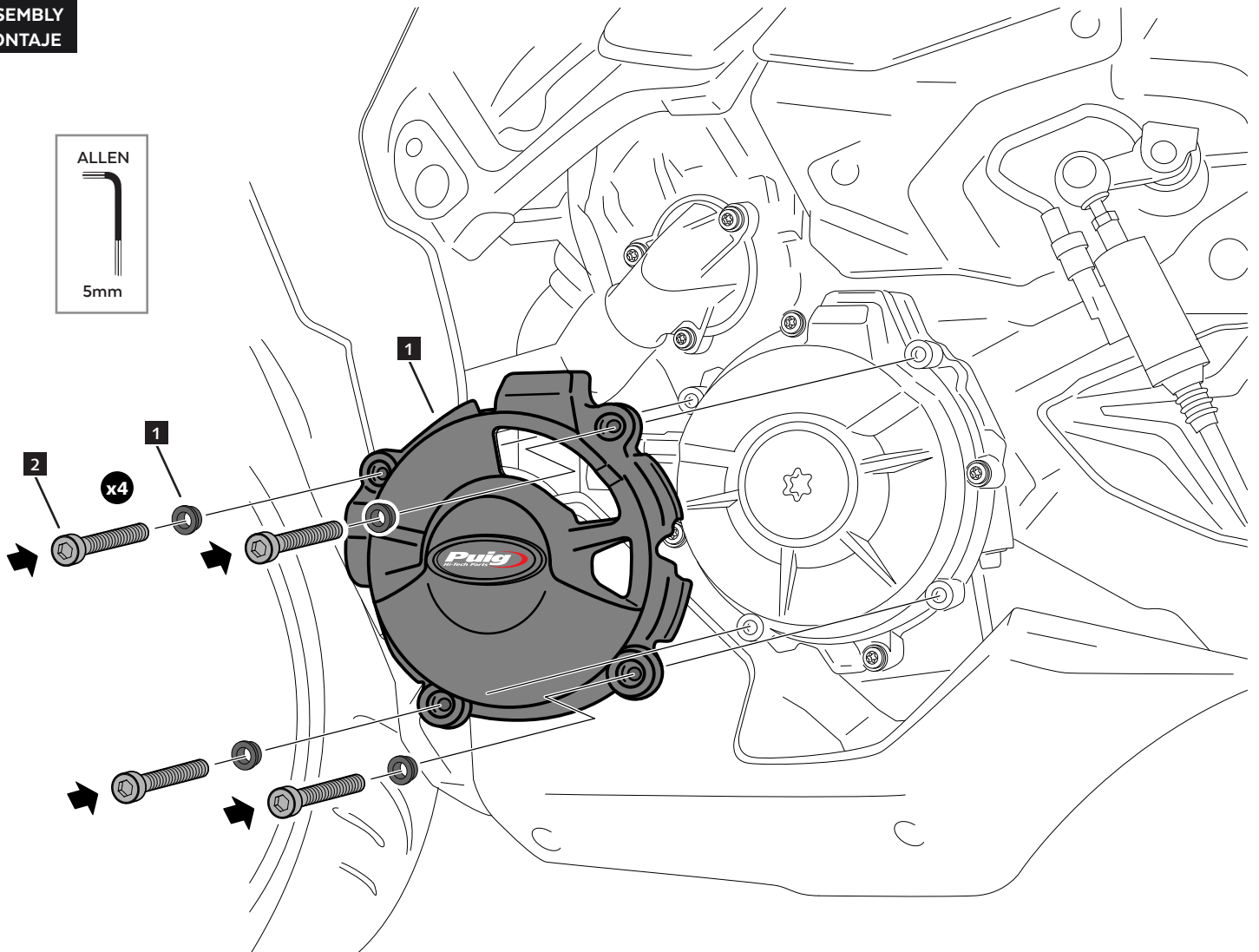

**CONSULTAR EN NUESTRA PAGINA WEB LA DISPONIBILIDAD DEL VIDEO DE MONTAJE DE ESTA REFERENCIA.
CONSULT OUR WEBSITE THE VIDEO MOUNT AVAILABILITY OF THIS REFERENCE.**

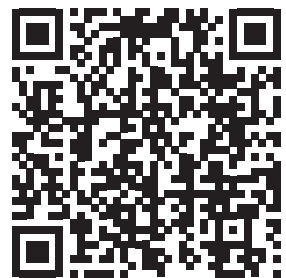

BMW S 1000XR '20-

REF 21241N

TAPAS LATERAL DERECHO / RIGHT SIDE COVERS



1 Person



30 min



EASY



ID.	PIEZA / PART	DESCRIPCIÓN	DESCRIPTION	QTY.	REF.:
1		Tapa derecha 1	Right cover 1	1	CONJUNTO--21241
2		Tapa derecha 2	Right cover 2	1	CONJUNTO--21241
3		Tornillo M6x15 DIN912	M6x15 DIN912 screw	1	-
4		Tornillo M6x40 DIN912	M6x40 DIN912 screw	5	-
5		Tornillo M6x45 DIN912	M6x45 DIN912 screw	1	-

RECOMENDAMOS MONTAR LOS TORNILLOS APRETANDO UNIFORMEMENTE UNO TRAS OTRO, PARA APRETAR FINALMENTE CON DINAMOMÉTRICA
WE RECOMMEND TO MOUNT THE SCREWS UNIFORMLY TIGHTENING ONE AFTER THE OTHER, TO FINALLY TIGHTEN WITH DYNAMOMETRIC

BMW S 1000XR '20-

REF 21241N

INSTRUCCIONES DE MONTAJE - MOUNTING INSTRUCTIONS - MONTAGEANLEITUNG

1

ASSEMBLY
MONTAJE

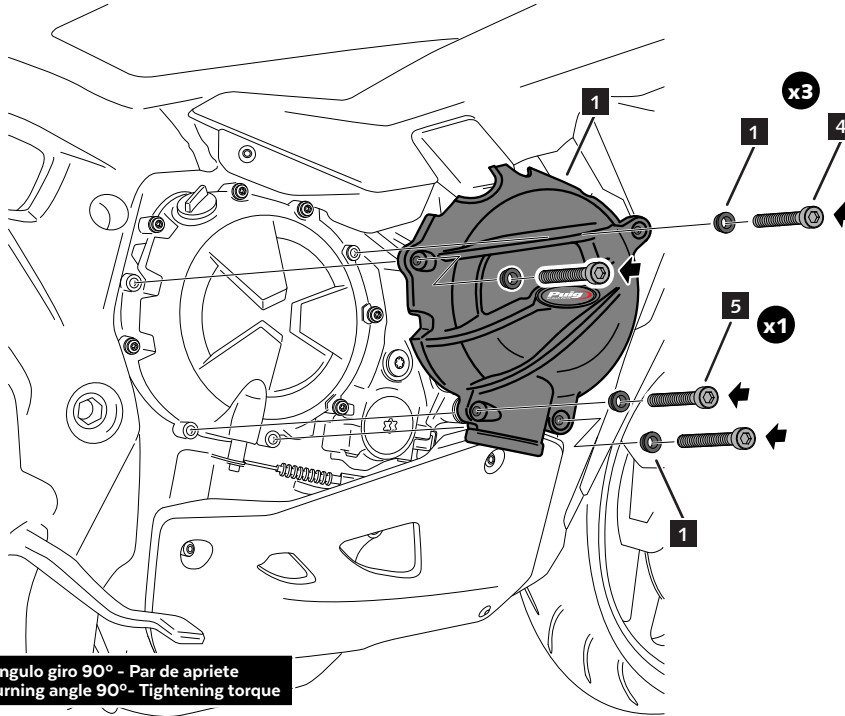
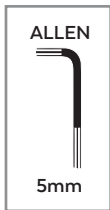

4-5  3,00 N/m + ángulo giro 90° - Par de apriete
2,21 lbf/ft + turning angle 90° - Tightening torque

2

ASSEMBLY
MONTAJE

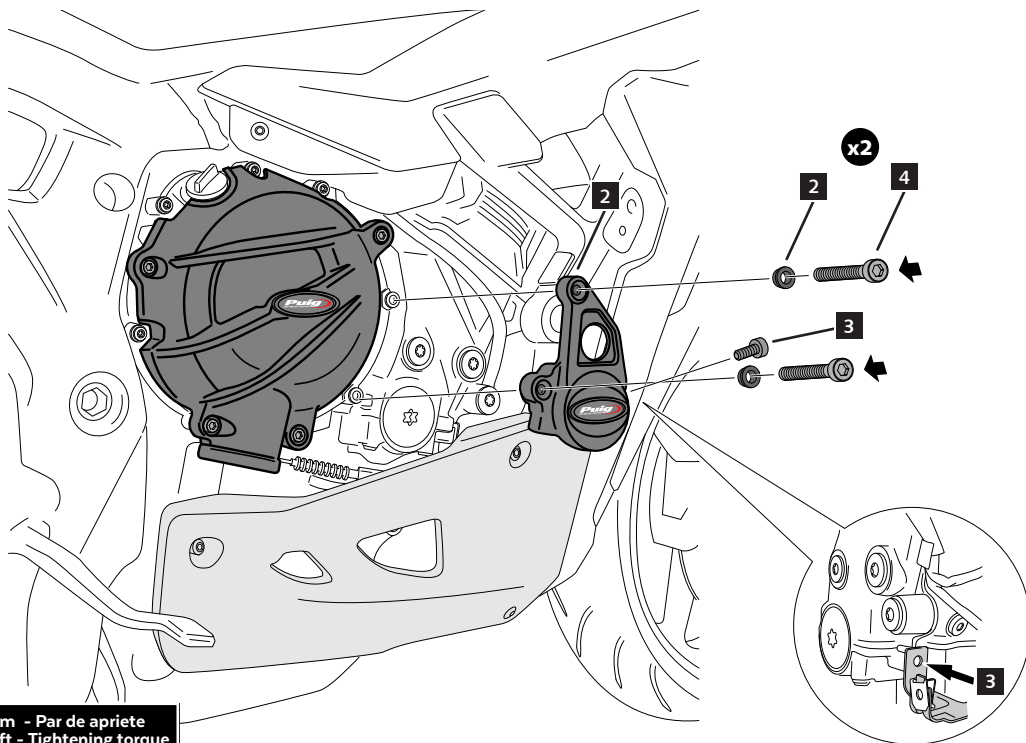

4  9,00 N/m - Par de apriete
6,64 lbf/ft - Tightening torque